



2-port valves  
VVP469.10-0.63 to VVP469.20-4



3-port valves  
VXP469.10-0.25 to VXP469.20-4



3-port valves with bypass  
VMP469.10-0.63 to VMP469.15-4



## 2-port and 3-port small valves PN 16

**VVP469..**  
**VXP469..**  
**VMP469..**

- VVP469.., VXP469..      brass valve body  
VVP469.15-4, VMP469..    bronze CC491K (Rg5) valve body, max 4% pB
- DN 10, DN 15 and DN 20
- $k_{vs}$  0.25/0.63...4 m<sup>3</sup>/h
- Flat seal male threaded connections G..B to ISO 228-1 for
  - ALG.. screwed fitting sets with thread connection      (available from Siemens)
  - SERTO compression fittings, type SO 00021..      (available from trade suppliers)
  - Screwed copper fittings      (available from trade suppliers)
- Manual adjuster (VXP469... and VMP469...)
- Can be equipped with type STA.., electrothermal or type SFA.., SUA21/1 or SSA... electromotive actuators

### Use

- In ventilation and air conditioning systems for water-side terminal unit control in closed circuits, e.g. induction units, fan coil units, small reheaters and small recoolers, for use in:
  - 2-pipe systems with one heat exchanger for heating and cooling
  - 4-pipe systems with two separate heat exchangers for heating and cooling
- In closed circuit zone heating systems, e.g.
  - Individual zones in a building
  - Apartments

## Individual rooms

### Type summary

VVP469.. 2-port	VXP469.. 3-port	VMP469.. 3-port with bypass	DN	Connections		$k_{vs}$ AB – A [m <sup>3</sup> /h]	$k_{vs}^{1)}$ AB – B [m <sup>3</sup> /h]	$S_v$
				[inch]	Copper pipe dia. [mm]			
	VXP469.10-0.25		10	G½B	14.2 +0.2/-0	0.25	0.18	> 10
	VXP469.10-0.4					0.4	0.28	
VVP469.10-0.63	VXP469.10-0.63	VMP469.10-0.63				0.63	0.44	
VVP469.10-1	VXP469.10-1	VMP469.10-1				1.0	0.70	
VVP469.10-1.6	VXP469.10-1.6	VMP469.10-1.6				1.6	1.12	
VVP469.15-2.5	VXP469.15-2.5	VMP469.15-2.5	15	G¾B	18.2 +0.2/-0	2.5	1.75	
VVP469.15-4		VMP469.15-4				4.0	2.80	
VVP469.20-4	VXP469.20-4					20	G1B	

1) Valid for 3-port version only. The  $k_{vs}$ -values represent 70 % of the AB → A nominal flow rate.

DN = Nominal size

$k_{vs}$  = Nominal flow rate of cold water (5...30 °C) through the fully open valve ( $H_{100}$ ) by a differential pressure of 100 kPa (1 bar)

$S_v$  = Rangeability  $k_{vs} / k_{vr}$

$k_{vr}$  = Smallest  $k_v$  value, at which the flow characteristic tolerances can still be maintained, by a differential pressure of 100 kPa (1 bar)

### Accessories

Type reference	Description
ALG..2	Set of 2 screwed fittings for 2-port valves, consisting of - 2 union nuts - 2 discs and - 2 flat seals
ALG..3	Set of 3 screwed fittings for 3-port valves, consisting of - 3 union nuts - 3 discs and - 3 flat seals
AL50	Supporting ring for SFA... and SUA... actuators

### Order

When ordering please give quantity, product name and type reference.

Example:

15 3-port valves with bypass VMP469.10-1

30 sets of screwed fittings ALG132

For 3-port valves with bypass VMP469.., order two sets ALG..2 of 2 screwed fittings.

### Delivery

The valves are supplied in optimized multipacks with minimum order quantities accordingly.

Valves, actuators and accessories are packed and supplied separately.

Type	Quantity per package
VVP469.10-0.63 - VVP469.10-1.6	24
VXP469.10-0.25 - VXP469. 10-1.6	
VMP469.10-0.63 - VMP469.15-4	15
VVP469.15-2.5 - 20-4	20
VXP469.15-2.5 - 20-4	
AL50	40

## Equipment combinations

Valves	Electromotive actuators						Electro-thermal actuators		Sets of screwed fittings Siemens <sup>2)</sup>		
	SUA21/1		SFA.. <sup>1)</sup>		SSA..		STA..		Male thread	Female thread	
	$\Delta p_{max}$	$\Delta p_s$	$\Delta p_{max}$	$\Delta p_s$	$\Delta p_{max}$	$\Delta p_s$	$\Delta p_{max}$	$\Delta p_s$			
	[kPa]										
VVP469.10-0.63..1.6	200	300	200	300	100	150	200	200	ALG132		
VVP469.15-2.5							150	150	ALG142		
VVP469.15-4							200	200			ALG152
VVP469.20-4											
VXP469.10-0.25..1.6	200		200		100		200		ALG133		
VXP469.15-2.5							150		ALG143		
VXP469.20-4							200				ALG153
VMP469.10-0.63	200		200		100		200		ALG133		
VMP469.10-1									ALG133		
VMP469.10-1.6									ALG133		
VMP469.15-2.5									ALG143		
VMP469.15-4							150		ALG143		
Data sheet	N4830		N4863		A6V11858276		N4884				

<sup>1)</sup> AL50 needed for mounting SFA... actuator

<sup>2)</sup> Thread on pipe side

$\Delta p_{max}$  = Maximum permissible differential pressure across the valve, valid for the entire actuating range of the motorized valve.

$\Delta p_s$  = Maximum permissible differential pressure at which the motorized valve closes securely against pressure (close off pressure).

## Actuator overview

Type reference	Actuator type	Operating voltage	Positioning signal	Positioning time	Positioning force	
STA23MP/00 <sup>2)</sup>	Electro-thermal	AC 230 V	2-position	210 s	100 N	
STA73MP/00 <sup>2)</sup>		AC/DC 24 V	(2-position, PDM <sup>1)</sup> )	270 s		
STA63		AC 24 V	DC 0...10 V	270 s <sup>3)</sup>		
SFA219/18	Electro-motive	AC 230 V	2-position (On/Off)	10 s	200 N	
SFA719/18		AC 24 V	with spring return			
SUA21/1		AC 230 V	SPST <sup>4)</sup>		150 N	
SSA331.00			3-position	67.5 s	100 N	
SSA161.05			AC/DC 24 V	DC 0...10 V		25 s
SSA131.00			AC 24 V	3-position		67.5 s

<sup>1)</sup> PDM = Pulse duration modulation in conjunction with room controllers

<sup>2)</sup> Packaging unit: 50 pieces (OEM) without cable, must be ordered separately

<sup>3)</sup> Min. runtime ca. 30 s/mm in control mode (heat-up time)/mm

<sup>4)</sup> SPDT = Single Pole, Double Throw

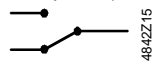

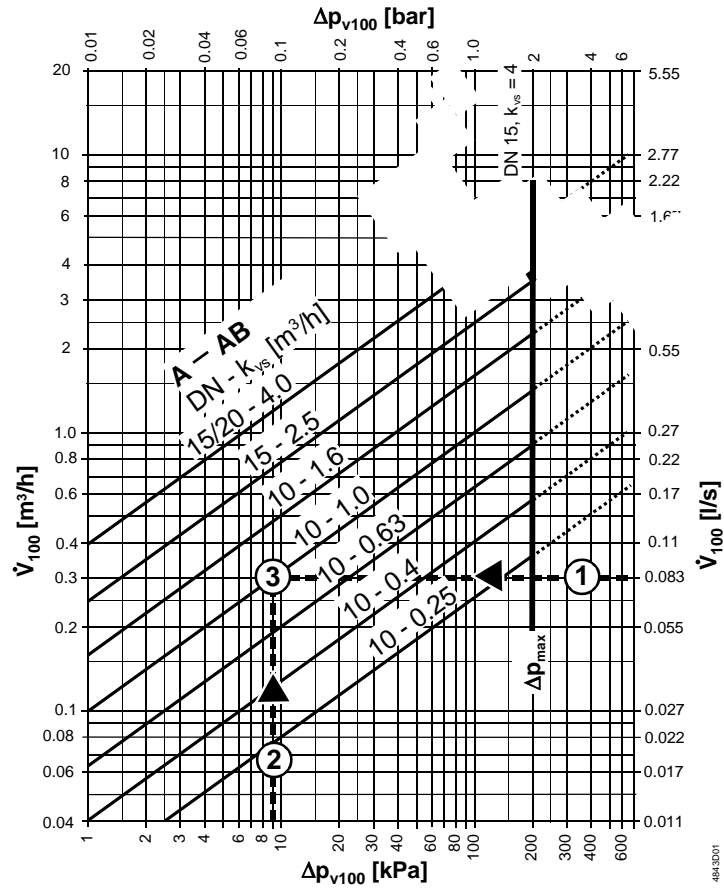

- $\Delta p_{max}$  = Maximum permissible differential pressure across the valve, valid for the entire actuating range of the motorized valve
- $\Delta p_{v100}$  = Differential pressure across the fully open valve and the valve's control path by a volume flow  $\dot{V}_{100}$
- $\dot{V}_{100}$  = Volume flow through the fully open valve ( $H_{100}$ )
- 100 kPa = 1 bar  $\approx$  10 mWC
- 1 m<sup>3</sup>/h = 0.278 l/s water at 20 °C

**Example:**

1	$\dot{V}_{100}$	=	0.083 l/s
2	$\Delta p_{v100}$	=	9 kPa
3	Required $k_{vs}$ -value	=	1.0 m <sup>3</sup> /h

**Valve flow characteristic**

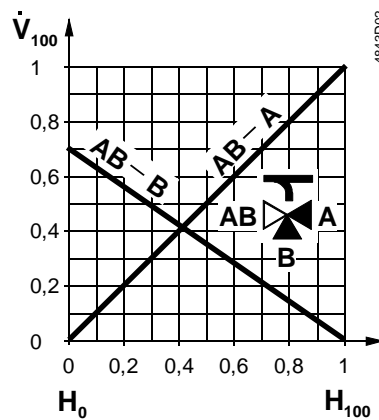

The  $k_{vs}$ -values in bypass B for valve types V..P469.. represent only 70 % of the  $k_{vs}$ -value in the straight-through control path  $AB \rightarrow A$ . This compensates for the flow resistance of the heat exchanger or radiator, thus keeping the overall flow rate,  $\dot{V}_{100}$  as constant as possible.



**Do not mount a shutoff on bypass port B.**

Recommendation:

Always use a strainer upstream of the valve to increase the valve's functional safety.

Valve construction	Function	Valve flow in control mode		Valve stem	
		Inlet A	Outlet AB	Retracted	Extended
VVP469.. 		variable	variable	A → AB closes	A → AB opens

**Warning!** The direction of flow **MUST** be as indicated by the arrow, from A → AB.

Valve construction	Function diverting	Valve flow in control mode			Valve stem	
		Port AB	Port A	Port B	Retracted	Extended
VXP469.. 		Inlet: constant	Outlet: variable	Outlet: variable	AB → A closes  AB → B opens to 70 %	AB → A opens  AB → B closes
VMP469.. 		Inlet: constant	Outlet: variable	Outlet: variable	AB → A closes  AB → B opens to 70 %	AB → A opens  AB → B closes

**Warning!** VXP469.. and VMP469.. are diverting valves; they cannot be used as mixing valves. The direction of flow **MUST** be as indicated by the arrow, from **AB → A** and **AB → B**.

**Mounting instructions**

The valve and actuator are easily assembled directly on site without need for special tools or calibration.

Mounting Instructions 74 319 0271 0 are enclosed with the multipack.

Orientation

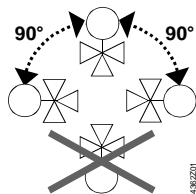

AL50 supporting ring

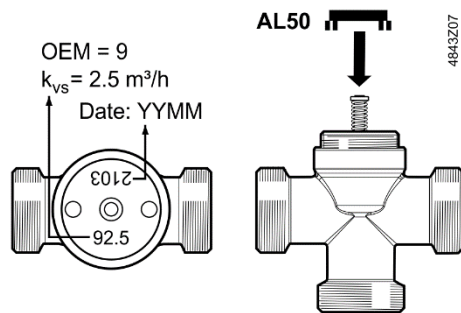

The AL50 supporting ring must be positioned prior to mounting the SFA... actuator onto the valve.

## Commissioning notes



**Resume valve operation only if the manual knob or actuator has been mounted correctly.**

### Manual adjustment

Using the manual adjuster or actuator allows for opening through-port AB ↔ A of the valve. With three-port valves, this throttles or closes bypass B. Through-port AB → B (bypass B) can be opened between 0% and max.70% manually. The valves are opened using their own spring (normally open).

## Maintenance



V..P469.. valves require no maintenance.

When servicing the valve/actuator:

- Deactivate the pump and turn off power
- Close the shut-off valves
- Fully reduce pressure in the piping system and allow pipes to completely cool down. If necessary, disconnect the electrical wires.

Before resuming valve operation, make sure the manual knob or the actuator is fitted properly.

### Stem sealing gland

The stem sealing gland cannot be exchanged. In case of leakage, the entire valve must be replaced. Contact your local office or branch.

### Disposal



Prior to disposal, dismantle the valve and separate it into its various constituent materials.

Legislation may demand special handling of certain components, or it may be sensible from an ecological point of view.

**Comply with all local, applicable laws.**

## Warranty

The technical data for these applications is valid only together with Siemens actuators as described in "Equipment combinations".

**Use with third-party actuators expressly voids any warranty offered by Siemens Switzerland Ltd / HVAC Products.**

## Technical data

Functional data	PN class	PN 16 to EN 1333
	Permissible operating pressure	1600 kPa (16 bar)
	Valve flow characteristic	
	Through-port AB → A (0...100%)	Linear
	Bypass AB → B (0...70%)	Linear
	Leakage rate	As per DIN EN 1349
	Through-port AB → A	0...0.05 % of $k_{vs}$ -value
	Bypass B	Max. 2...5% of $k_{vs}$ -value
	Permissible media	Low temperature hot water, chilled water, water with anti-freeze; recommendation: water treatment to VDI 2035
	Medium temperature	1...110 °C
	Rangeability $S_v$	> 10
Nominal stroke	2.5 mm	
Standards	Pressure Equipment Directive	PED 97/23/EC
	Pressure accessories	As per article 1, section 2.1.4
	Fluid group 2	Without CE-marking as per article 3, section 3 (sound engineering practise)
Materials	VVP469... and VXP469.. valve body	Brass
	VVP469.15-4 and VMP469.. valve body	Bronze CC491K (Rg5) max. 4% pB
	Stem	Stainless steel
	Plug, seat, gland	Brass or bronze CC491K (Rg5) max. 4% pB
	Sealing gland	EPDM-O-rings
Dimensions / Weight	Dimensions	Refer to "Dimensions"
	Threaded connections	Valve G..B as per ISO 228-1
		Screwed fittings R/Rp.. as per ISO 7-1, G.. as per ISO 228-1
	Actuator connection	M30 x 1.5
	Weight	Refer to "Dimensions"
Accessories	ALG.. screwed fittings (supplier: Siemens)	Nut, nipple and flat seal for steel pipes with gas-pipe threads
	SERTO SO 00021.. screwed fittings (available from suppliers to the trade)	Nut and compression fitting for seamless copper and mild-steel piping
	Copper pipe connections screwed fittings (available from suppliers to the trade)	For welded copper pipes

## Dimensions

### 2-port valves

VVP469..

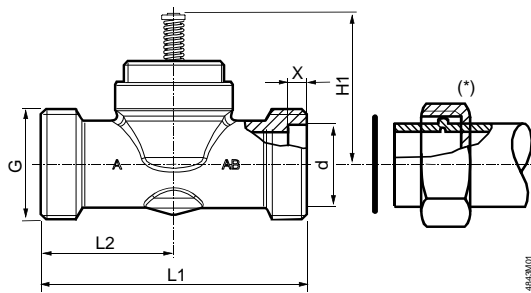

### 3-port valves

VXP469..

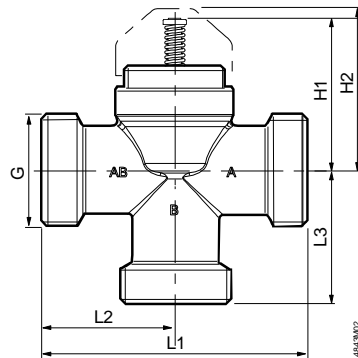

### 3-port valves with bypass

VMP469..

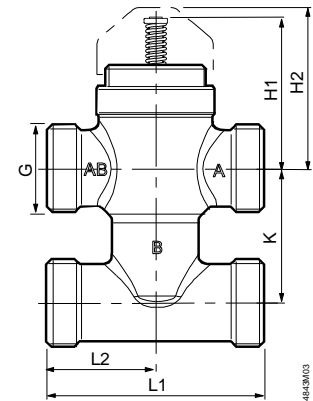

(\*) Compression fitting for welded copper pipes (available from suppliers to the trade)



Type reference	DN	G [inch]	d [mm]	X [mm]	H1 [mm]	L1 [mm]	L2 [mm]	Weight [kg]
VVP469.10-0.63...1.6	10	G½B	14.2 +0.2/-0	5 +0/-0.2	45.2	60	30	0.22
VVP469.15-2.5	15	G¾B	18.2 +0.2/-0			65	32.5	0.25
VVP469.15-4						80	40	0.30
VVP469.20-4	20	G1B	22.2 +0.2/-0			80	40	0.32

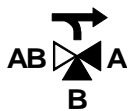

Type reference	DN	G [inch]	d [mm]	X [mm]	H1 [mm]	H2 [mm]	L1 [mm]	L2 [mm]	L3 [mm]	Weight [kg]
VXP469.10-0.63...1.6	10	G½B	14.2 +0.2/-0	5 +0/-0.2	45.2	48	60	30	30	0.27
VXP469.15-2.5	15	G¾B	18.2 +0.2/-0				65	32.5	32.5	0.29
VXP469.20-4	20	G1B	22.2 +0.2/-0				80	40	40	0.40

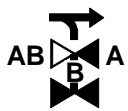

Type reference	DN	G [inch]	d [mm]	X [mm]	H1 [mm]	H2 [mm]	L1 [mm]	L2 [mm]	K [mm]	Weight [kg]
VMP469.10-0.63...1.6	10	G½B	14.2 +0.2/-0	5 +0/-0.2	45.2	48	60	30	40	0.38
VMP469.15-2.5	15	G¾B	18.2 +0.2/-0				65	32.5		0.46
VMP469.15-4							80	40		0.44

## Screwed fittings

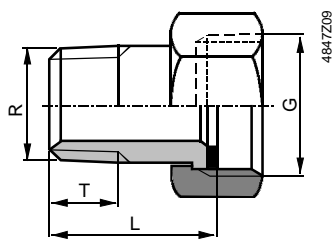
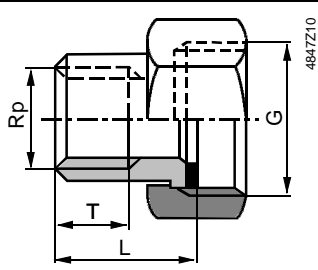
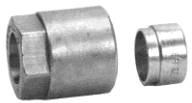
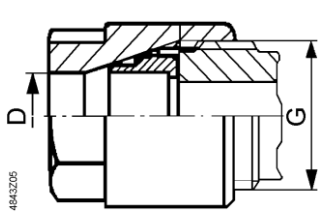
<p><b>Sets of screwed fittings with flat seal</b></p> <p>available from Siemens</p> <p>ALG...2: Set of 2 screwed fittings</p> <p>ALG...3: Set of 3 screwed fittings</p>	<p>ALG132 ALG133 ALG142 ALG143</p> <p>With male thread on tube side</p> 
	<p>ALG152 ALG153</p> <p>With female thread on tube side</p> 
<p><b>Compression fittings</b></p>  <p>Available from other suppliers</p>	<p>SERTO SO 00021..</p> 

ALG... type	For valve type	DN	G [inch]	R [inch]	Rp [inch]	L [mm]	T [mm]	SERTO type SO 00021.. <sup>1)</sup> <a href="http://www.serto.com">www.serto.com</a>	D [mm]
ALG132	VVP469.10-0.63...1.6	10	G½	R¾		≈ 24	≈ 9	SO 00021-12-1/2"	12
ALG133	VXP469.10-0.25...1.6							SO 00021-14-1/2"	14
2 x ALG132	VMP469.10-0.63...1.6							SO 00021-15-1/2"	15
ALG142	VVP469.15-2.5...4	15	G¾	R½		≈ 29.5	≈ 12	SO 00021-17-3/4"	17
ALG143	VXP469.15-2.5							SO 00021-18-3/4"	18
2 x ALG142	VMP469.15-2.5...4								
ALG152	VVP469.20-4	20	G1		Rp½	≈ 23	≈ 13		
ALG153	VXP469.20-4								

<sup>1)</sup> SO 00021-17.. and SO 00021-18 on request

DN = Nominal size

G = Valve thread (internal cylindrical)

D = External diameter for seamless copper and mild-steel piping

Issued by  
Siemens Switzerland Ltd  
Smart Infrastructure  
International Headquarters  
Theilerstrasse 1a  
6300 Zug  
Switzerland  
Tel. +41 58-724 24 24

[www.siemens.com/buildingtechnologies](http://www.siemens.com/buildingtechnologies)

© Siemens Switzerland Ltd, 2008

Technical specifications and availability subject to change without notice.